



Spritzgiessautomaten



**GREAT MACHINES —
compactly designed**

Products

Strength by concentration

More than 40 years of well-proven technology



BOY stands for full service right from the start:

- Competent advice, individual solutions
- Showrooms for live performances and individual test series
- Mould tests under operational conditions
- Short delivery times
- Complete service from start-up and training
- Permanent service availability, smooth handling
- Efficient spare parts service
- Extensive offer of preventive maintenance measures
- Various training programmes

Ever since the company was founded in 1968, BOY have concentrated on their strong points: Development and manufacturing of injection moulding machines within a clamping force range below 1000 kN. The result of this concentration is an extensive programme which is used in different industrial sectors for various applications.

Thousands of customers have chosen BOY injection moulding machines. Worldwide, the robust machines are well known for their reliability, precision, and efficiency - quality "Made in Germany".

The current programme is characterized by a perfectly balanced design which is thought through to the most minute detail. The basis for the extra-ordinarily favourable price/performance ratio is the volume production of specialized parts.

The most important design characteristics of BOY injection moulding machines have been maintained since 1968:

- Cantilevered two-platen clamping system
- Fully hydraulic drive system
- State-of-the-art control techniques
- Compact design

Continuity and know-how will continue to ensure high standards for precise control and economical production.

Convincing arguments The BOY product range

BOY's design principles have left their mark in more than 40,000 machines:

Maximum flexibility

No other machine design offers more freedom than the two-platen clamping system - for example the two-platen design is ideally suited for compact clean room applications, automation, and integration into production environments.

Small footprint

The compact design and the easy accessibility of all components reduce the actual space requirement by almost one-third. Therefore, more machines can be placed into a specified area.

Optimum production conditions

Easy access to all machine components, the mould area, and the peripheral equipment, as well as easy handling of the moulded parts reduce set-up times and simplify production and maintenance.

Large mould fixing dimensions

BOY injection moulding machines feature top values regarding tie bar and platen distances. In most cases, moulds can be installed that exceed the values customary for the respective clamping force class by one standard mould unit.

Flexible mould use

Multiple bolt-hole patterns on the fixed platen ensure a secure installation of various existing moulds.

Intuitive control system

Touch screen operation with graphical guidance through the menus and ultra-fast screen page construction guarantee rapid and faultless operation.

Comfortable operation

An ergonomical working height, as well as easy accessibility of moulds, injection unit, and all other structural units combine to make the operation of a BOY injection moulding machine very simple.

Minimum energy consumption

The saving potential of BOY injection moulding machines with servo-motor pump drive amounts to more than 50 percent.

Low cooling capacity

BOY injection moulding machines require less cooling capacity than comparable machinery. Consequently, fast cycles can be run without additional costs for cooling.

The universal BOY machine concept:



The top model of the current BOY programme: The BOY 90 with 900 kN clamping force, 280.5 cm³ injection volume, daylight between tie bars 430 x 360 mm, as well as 900 mm maximum platen distance (optional)

Procan ALPHA® - control at the highest level

Optimal operation – fast and precise

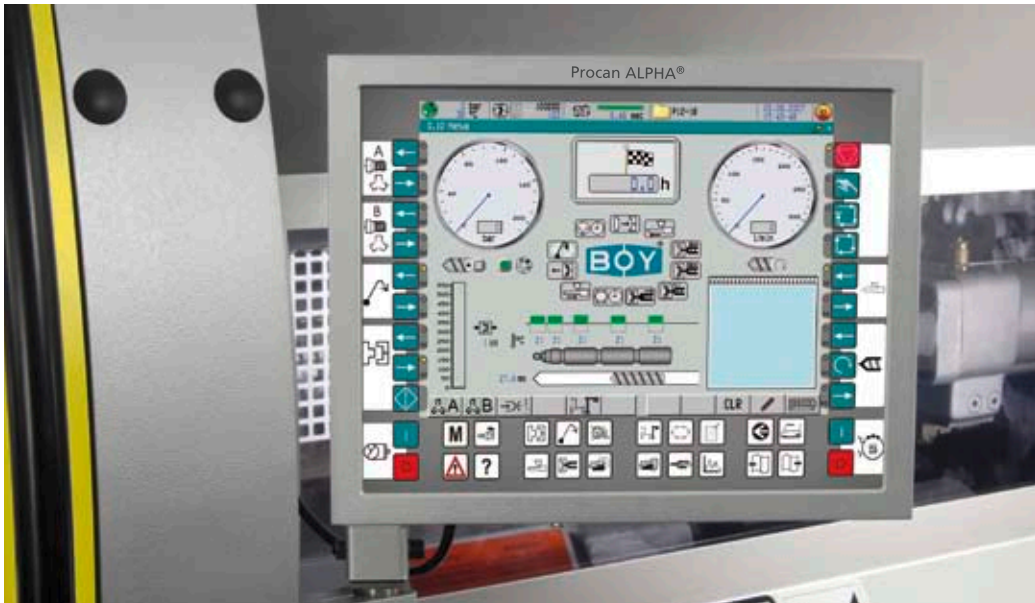

Innovation with tradition

A decisive element for precision and efficiency of an injection moulding machine is its control.

With the Procan generation of controls, BOY has set standards. Innovative hardware solutions and ease of operation are the advantages of the Procan controls. Beginning in 1998, BOY introduced touch screen operation via screen menus; high-performance 32 BIT processors have been a reliable standard for many years.

With the Procan ALPHA® control, BOY presents an ultra-modern generation of machine controls. This new development not only takes advantage of the latest technical options, but furthermore incorporates numerous suggestions and advice by our customers. Thus, the Procan ALPHA® control combines innovative technology with years of practical experience and continues in the tradition of successful Procan controls.

Technology – for tomorrow's products

Special features of the control technology are a UTX PC system (with one circuit board), a freely programmable hardware module, and the Iterativ Learning Controller (ILC).

While the computer takes over all functions of the control in real-time mode, the newly developed hardware module relieves it from all time-relevant tasks. This novel hardware module carries out without delay, but with utmost precision extensive calculation processes, which keep coming up during injection moulding and have an influence on the processing speed of customary, computer-assisted machine controls.

Most simple operation Maximum information

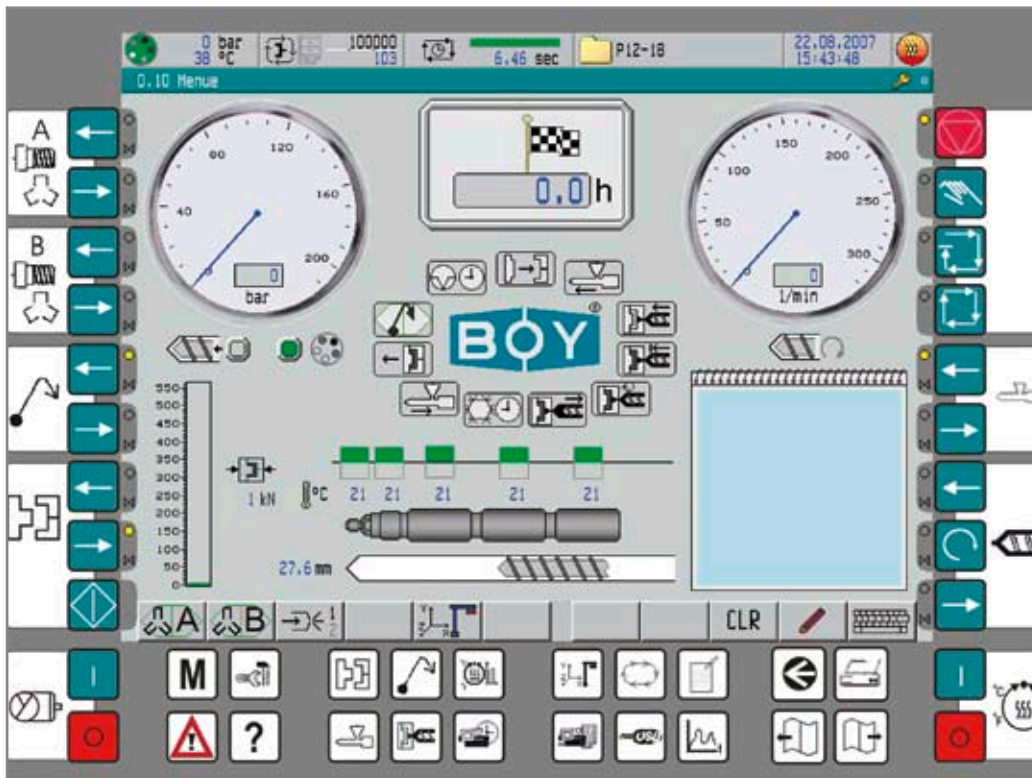

Clear and logical screen pages with little text and easily remembered symbols ensure rapid and intuitive operation

Safe handling

Only those users who have been authorized in advance may access the Procan ALPHA® control. Release is either effected by entering a password or via USB flash drive.

A logbook saves all changes of set values by time and name. Therefore, the logbook will show who made what change at what time.

Ease of operation

The Procan ALPHA® is operated over the entire surface of a 15" full-touch display. Construction and change of screen pages approach record times.

The specially designed menu guide further contributes to an extremely fast operation and

shortest possible set-up times. Error-free operation is enabled by the graphical operator prompt and an illustration largely without text.

A central survey page contains all important information to obtain a quick overview of the current machine status. It furthermore offers rapid access to selected screen pages.

If required, brief messages can be stored on an electronic notepad.

A freely configurable screen page allows the user, for example, to clearly arrange all relevant set and actual values on one page.

Perfect design and function

Well designed equipment leaves nothing to be desired

Operating instructions with troubleshooting guide

Compact instruction manuals are stored, complete with the causes for faults as indicated by the different warning codes and the respective corrective measures. Time consuming browsing through printed manuals is thus no longer necessary.

Interfaces

The machine software already includes all prerequisites for Ethernet and OPC data transfer.

An optional interface package enables a connection to networks and remote diagnosis systems. Also included are a second USB interface to link up a printer and the connections for up to four temperature control units via serial interface. FTP and web servers round off the possibilities of this interface package.



The Procan ALPHA® does not require keys; entries are made exclusively via touch screen

In addition to precise functions, the Procan ALPHA® control also offers a multitude of new developments:

Optimum operation

- Access control by password or USB flash drive
- Easy control via full-touch display
- Extremely fast screen construction by means of real-time operating system
- Graphical menu guide for intuitive, error-free operation
- Graphics editor for simplified entry of profiles
- Configuration page, displaying the programmed machine sequence and all auxiliary functions
- Configurable screen page for individual evaluation
- Electronic notepad

Perfect results

- Dynamic mode of operation for shorter start-up phase and less start-up rejects
- Shorter cycle times, due to dynamic controlling and reduced down times
- Optimized measuring and checking methods (actual value curve, temperature control, et cetera)
- Complete logbook for documentation
- Enlarged core pull programmes
- Ethernet and USB connections

Precise control using Procan ALPHA®

The new top technology by BOY

Unparalleled precision

The Iterative Learning Controller (ILC) enables a nearly faultless repeatability of the set values. While the customary process control merely reacts to the actual values, the ILC calculates the respective, optimum set-up value for the following cycles from the repetitive machine movements. In a way, the control learns by looking ahead, based on the machine movements, and thus optimizes itself. By that means, even the most difficult setting profiles are precisely repeated by the machine.

Already after three to five cycles, external alterations of the set values, as well as tolerances within the machine are compensated, such as changes in temperature and pressure, state of lubrication, humidity, material properties. Furtive deviations are rapidly and precisely balanced with this control technology.

Expanded range of functions

With the Procan ALPHA®, significantly expanded core pull programmes can be realized. Core pulls can be used for all functions and are no longer restricted to the opening or closing of the mould alone. Thus, less special programmes for the control of core pull functions are needed.

Extensive functions for the actual value curve markedly increase production reliability. For example, they act as a background control, checking the complete injection process. Upon deviations from tolerances which can be individually set, either alarm signals can be triggered, or the machine can be switched off completely.

With the Procan ALPHA®, the temperature control is optimized with each start up. Optional use of various heating elements is just as possible as the adaptation of the temperature control without entry of the PID parameters. The temperatures of the nozzle and nozzle mount heatebands can be controlled separately.

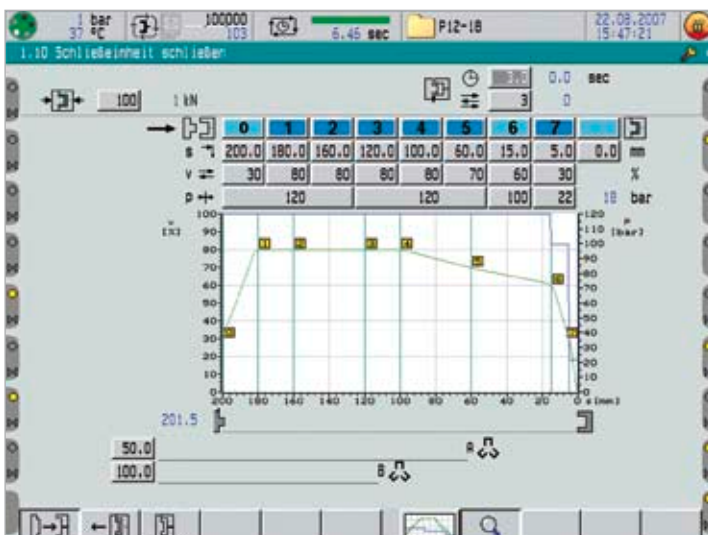

With the integrated graphics editor, setting profiles can be rapidly and easily entered or altered.

Electronically controlled, variable displacement pump For BOY XS, BOY 22 and BOY 35

The fully hydraulic drive of the A-series is equipped with an electronically controlled, variable displacement pump. The pump operates at a constant speed, thus ensuring a harmonious low energy consumption operation. The variable displacement pump feeds the required amount of oil depending on the cycle and adjusts the pressures as required.

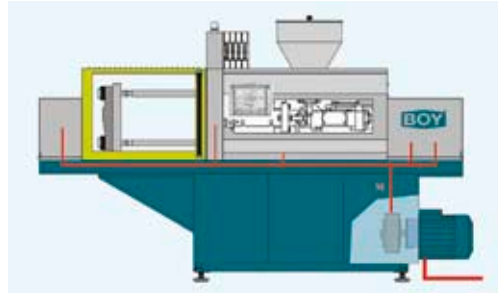

Servo-Motor Pump Drive For BOY 55 E and BOY 90 E

The injection moulding machines of the E-Series are our top models. The essential innovation is the servo-motor pump drive.

BOY has always taken the lead in energy-efficient solutions. The introduction of the servo-motor pump drive now marks another significant breakthrough in this regard.

A gear pump is driven by a special servo motor. Volume and pressure are controlled dynamically by adjusting the motor speed. This means that when neither oil nor pressure are needed, the

motor switches off and no longer requires energy.

The kinetic energy resulting from the slowing-down is partly stored in the intermediate circuit of the converter and re-used for the next function, e. g. acceleration of an axis.

Due to the combined effect of the highly efficient motor and the special converter control, as well as a motor speed adapted to the required volume throughput, the pump always maintains an optimum mode of operation.

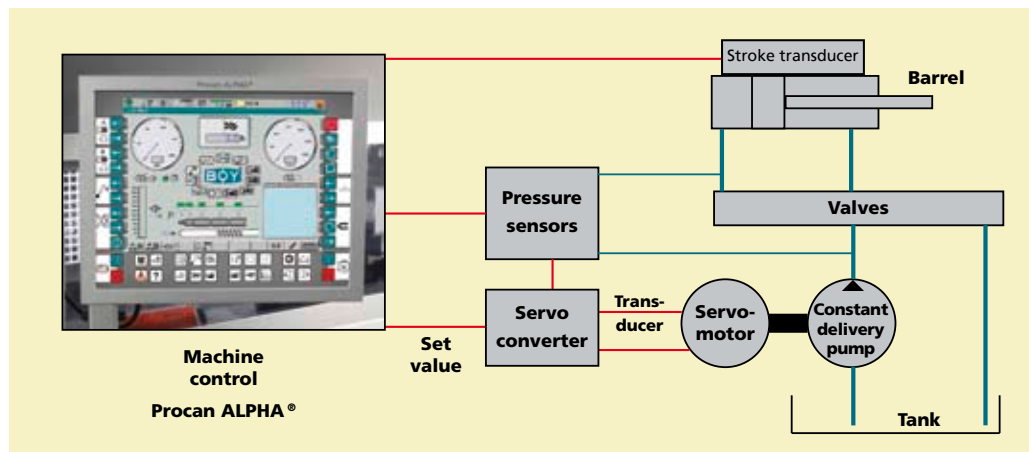

The distinctive feature of the system as a whole (converter / motor / pump) is its compact design.

Energy-saving drive technology

Basic data for the cost comparison on the right is as follows:

- Annual degree of utilization: 6,000 h
- Depreciation over 5 years
- Cost for space: € 60.00 per m²
- Energy cost: € 0.10/kWh
- Maintenance rate: 5 %
- Interest rate: 6 %

BOY injection moulding machines work with high precision, are compact, and can easily be equipped for automation. Also decisive are very low operating costs and extremely low machine hour rates.

The above is achieved by:

- Favourable price / performance ratio of the machine
- Compact design
- Reliability and ease of maintenance
- Low energy consumption

Motor speed is always only as high as the respective cycle phase requires. At all times, the motor is thus performing in an optimum, energy-efficient way.

In the pressure control phase (holding pressure), the motor speed is always as low as possible so that in this situation too, only the amount of energy needed to maintain pressure control is consumed.

Due to this motor design, the heating-up of the motor is reduced to a minimum, necessitating less energy for cooling which is reflected in the overall efficiency.

Comparison of machine hour rates

(for machines with 500/550 kN clamping force)

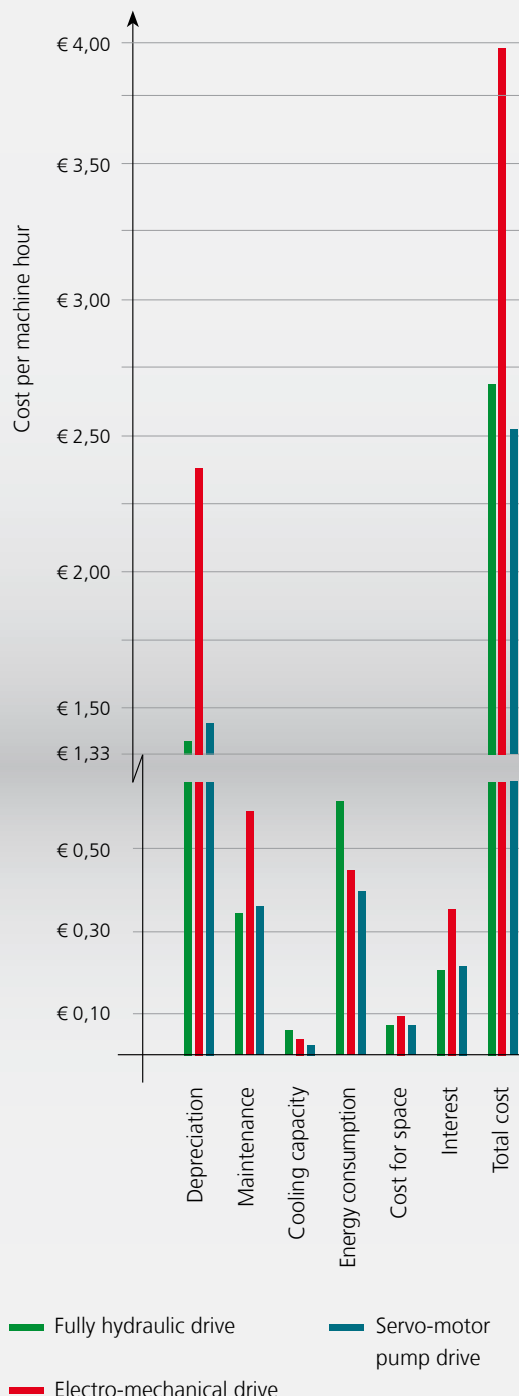

Comparison of drive systems

Distinct advantages for servo-motor drive

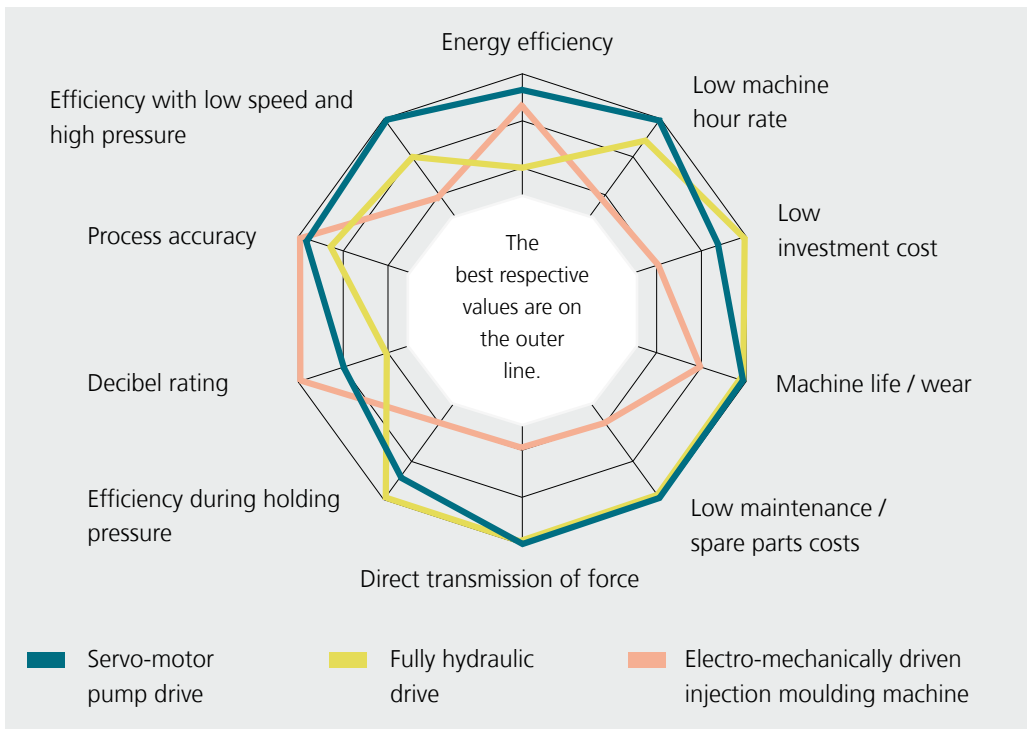

By using a servo-motor pump drive, it is possible to achieve and even surpass the positive features of electro-mechanical machines, without the disadvantages such as greater investment and spare parts costs and high connected load.

Compared to machines with electronically controlled variable displacement pump, the energy consumption of the drive is cut in half. It is even lower than that of electro-mechanical machines which, furthermore, have a markedly higher connected load.

This new drive technology also ensures that distinct improvements with regard to noise level, precision, and dynamics are achieved.

The noise level is reduced by up to 20 %. This is achieved by:

- Motor speed adapted to the respective situation. Consequently, the inactive motor-pump

unit between end of dosing and end of cooling time is absolutely noiseless.

- Special motor torque control.
- Use of constant delivery pumps.
- Prevention of pressure variations.
- Prevention of sudden changes to movement caused by the switch sequences of the valves.

Improved precision and dynamics are achieved by:

- Precise consistent acceleration and slow-down performance of the motor-pump unit. Response time is 70ms when altering the set value from standstill to full speed and thus to a maximum throughput rate. The reduction of speed is achieved with identical dynamics.
- The optimized motor with high torque features a low moment of inertia, as does the constant delivery pump.
- Converter with high reaction dynamics.

BOY XS injection moulding machine

Ideal for micro and sprueless, single-cavity injection moulding



Technical data

EUROMAP size:
100-14

Clamping force:
100 kN

Platen daylight:
250 mm

Opening stroke:
max. 150 mm

Tie bar clearance:
160 mm horizontal
205 mm diagonal

Shot weight (PS):
from 0,1 g until 5,6 g

Stroke volume (theoretical):
from 0,1 cm³ until 8,0 cm³

Screw diameter:
12, 14 and 16 mm

The BOY XS is a new development from BOY – an injection moulding machine designed with well-proven technology and all the merits of our larger machines.

The difference: the BOY XS is even more compact and thus offers new possibilities for micro and sprueless single-cavity injection moulding.

The BOY XS facilitates optimal automation solutions from granules right up to the finished and packaged moulded part – up to a shot volume of 8.0 cm³. The benefit for you: cost effectiveness combined with a supreme level of precision.

The intelligent design is ideally suited for the requirements of micro injection moulding. A 12 mm plasticizing unit and the innovative Procan ALPHA[®] control ensures absolute precision, repeatability, and ease of operation.

BOY's well-established, cantilevered two-platen clamping system reduces the space requirement to a minimum. The two diagonally arranged tie bars provide optimal access to the plasticizing unit, mould area, and ejector.

- Maximum performance in the smallest area
- More precise, most economical, extremely compact.
- Precise Procan ALPHA[®] control
- Easy to operate
- Easily adaptable to automated processes
- Designed for continuous industrial operation

BOY 22 injection moulding machine

Well-proven design



The BOY 22 and preceding models were the beginning of BOY's success story. Since 1968, more than 25,000 machines of this series have been operating worldwide in continuously improved and more efficient versions. This is proof of the high acceptance of a design which has been perfected to the last detail.

Characteristics of the BOY 22 are utmost reliability and extremely low machine hour rates. The very compact injection moulding machine (merely 2.4 m²) features a cantilevered clamping unit which offers easy access and room for individual options or automated systems. The construction is simple, clear, and ergonomic.

Two different sizes of injection units with altogether five different screw diameters offer a wide range of individual equipment options.

*Photo on the right:
BOY 22 HV with vertically arranged injection unit*

- Attractive price/performance ratio
- Robust, well thought-out design
- High efficiency through low machine hour rates
- Generous tie bar and platen distances
- Optional vertical configuration for parting-line injection



Technical data

EUROMAP size:
220-15 /
220-18 /
220-52

Clamping force:
220 kN

Platen daylight:
400 mm

Opening stroke:
max. 200 mm

Tie bar clearance:
254 mm

Max. shot weight (PS):
61,6 g

Max. stroke volume
(theoretical): 64 cm³

Screw diameter:
14, 18, 22, 24, 28
and 32 mm

BOY 35 injection moulding machine

Utmost precision



Technical data

EUROMAP size:
350-15 /
350-52 /
350-92

Clamping force:
350 kN

Platen daylight:
500 mm

Opening stroke:
max. 300 mm

Tie bar clearance:
280 x 254 mm

Max. shot weight (PS):
73,7 g

Max. stroke volume
(theoretical): 76,5 cm³

Screw diameter:
14, 18, 22, 24, 28
and 32 mm

The BOY 35 is a four-tie bar, fully hydraulic reciprocating-screw injection moulding machine with two-platen clamping unit. With its torsion-resistant clamping system and the high efficiency of the injection unit, the well-proven injection moulding machine is ideally suited for the production of precision parts within a narrow tolerance range.

With a required floor space of just over 2.7 square metres, the BOY 35 is more than just the most compact machine of its type; the price/performance ratio, too, is unparalleled. With the indisputably lowest machine hour rates, the BOY 35 is in no danger of having its top position threatened.

Three different-sized injection units allow individual adaptation of the machine performance, according to the task at hand.

- Four-tie bar, cantilevered two-platen clamping system
- Utmost precision for very low tolerances
- Ample space to install large moulds
- Easy access, ideally suited to incorporate optional equipment
- Maximum efficiency through favourable investment and operating costs
- Only 2.7 m² of floor space needed

BOY 55 E injection moulding machine

Performance up to 550 kN



Technical data

EUROMAP size:
550-52 /
550-79 /
550-205

Clamping force:
550 kN

Platen daylight:
650 mm

opening stroke:
max. 400 mm

Tie bar clearance:
360 x 335 mm (h x v)

Max. shot weight (PS):
158,9 g

Max. stroke volume
(theoretical): 166,3 cm³

Screw diameter:
18, 22, 24, 28, 32, 38
and 42 mm

With its appealing design, the BOY 55 is an optical highlight. But it is more than just optics which convinces the experts, namely its technical and operational values and its orientation towards cost-saving. Which is no surprise, for all the experience and innovative ideas BOY gained from decades of machine manufacturing went into the development of the BOY 55.

The result is a fully hydraulic injection moulding machine which is characterized by precision, performance, and compact design, simultaneously meeting the highest technical demands. The servo-motor pump drive for example ensures a very effective mode of operation which is smooth and energysaving at the same time. The patented pressure intensifier with integrated valve function reduces energy consumption to a minimum and guarantees secure clamping during the injection and cooling phases, without the need for a pressure sustaining pump.

- Servo-motor pump drive
- Four-tie bar, cantilevered two-platen clamping system
- Generous tie bar and platen distances
- Most exact positioning of the moving platen via proportional valve
- Easily accessible ejector at the rear of the moving platen
- Lateral swivel-out injection unit
- Robust machine frame with integrated oil tank
- Optimum L/D ratio of the screw
- Optional with SP 52 or SP 79 injection unit
- Different screws for thermoplastic, thermoset, LSR, and elastomer processing
- Compact design with little floor space needed

Convincing technology, perfect results: BOY 55

- 1 The machine design features the best ergonomics and efficient operation
- 2 The ejector chute, open on three sides, guarantees optimum evacuation of the moulded parts
- 3 Easy handling and flexibility with regard to additional equipment by the cantilevered clamping system
- 4 Optimum control technology with intuitive operation concept
- 5 Robust machine design with integrated oil tank

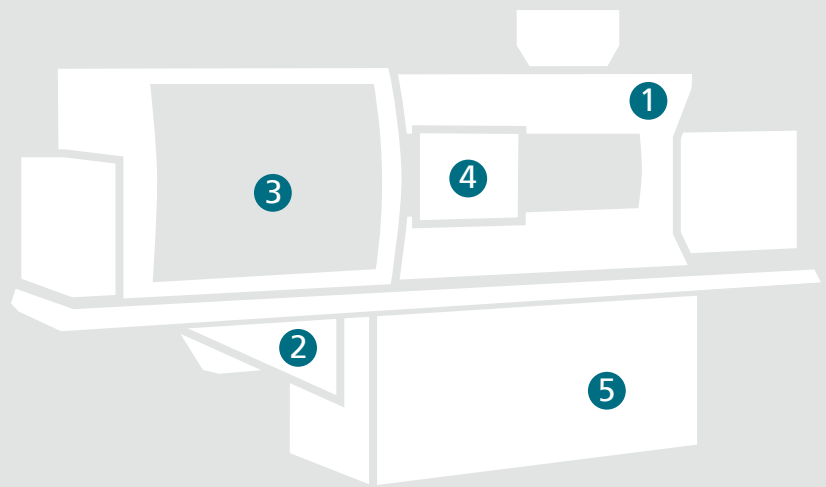

The extremely compact design of the BOY 55 significantly reduces the required floor space, compared to customary machines with a three-platen concept. Due to the cantilevered clamping unit, no additional space is needed for conveying systems or storage containers. Equipment for process automation or special assemblies for clean room applications, for example, can be mounted atop the BOY 55 in a space-saving manner.

Seven different screw diameters, injection units of three different sizes, and the suitability for a variety of injection moulding applications make the BOY 55 a machine for a multitude of purposes.

Available options include controls for brush units, unscrewing devices, core pulls, and integrated hot runner controls.



The swivel-out injection unit simplifies the retrofit procedure and maintenance.



By measuring the weight of 200 moulded components, the consistency of the parts and the repeatability of the machine were established.

The average value of the parts was 51.90 g. Thus the maximum deviation of 0.06 g (upwards as well as downwards) is only 0.115 % of the average value.

BOY 90 E injection moulding machine

BOY's top model



Technical data

EUROMAP size:
900-205 /
900-370

Clamping force:
900 kN

Platen daylight:
725 mm
(optional 900 mm)

Opening stroke:
max. 475 mm

Tie bar clearance:
430 x 360 mm (h x v)

Max. shot weight (PS):
252 g

Max. stroke volume
(theoretical): 280,5 cm³

Screw diameter:
28, 32, 36, 38, 42
and 48 mm

A little bit more of everything - that was the motto when the BOY 90 was developed. A greater daylight between tie bars (430 x 360 mm) and larger platen distances of 725 mm up to an optional 900 mm, as well as a clamping force of 900 kN characterize BOY's top model. And as befits a leader, the BOY 90 disposes of the same excellent properties all injection moulding machines from Neustadt-Fernthal feature.

Given the easy handling of the machine, the users of the BOY 90 enjoy maximum flexibility. All components - from the injection unit to the four-tie bar clamping system - are easily accessible.

The divided safety gate of the clamping unit is easy to open and offers optimum accessibility of the mould, which entails short set-up times and a rapid start of production.

Clearly designed menu structures offer maximum ease of operation with optimum results.

- Efficient working servo-motor pump drive
- Fully controlled
- Four-tie bar, cantilevered two-platen clamping system
- Patented pressure intensifier with integrated valve function
- Most exact positioning of the moving platen via proportional valve
- Divided safety gate for the clamping unit
- Easily accessible ejector
- Optimum L/D ratio of the screw
- Different screws for thermoplastic, thermoset, LSR, and elastomer processing
- Lateral swivel-out injection unit
- Robust machine frame with integrated oil tank

Convincing technology, perfect results: BOY 90

- 1 All structural units are easily accessible, making handling easier
- 2 Easy access of nozzle and plasticizing unit
- 3 Very efficient, yet smooth and energy-saving mode of operation through servo-motor pump drive
- 4 User-friendly touch-screen operation and process data recording
- 5 Robust machine design with integrated oil tank

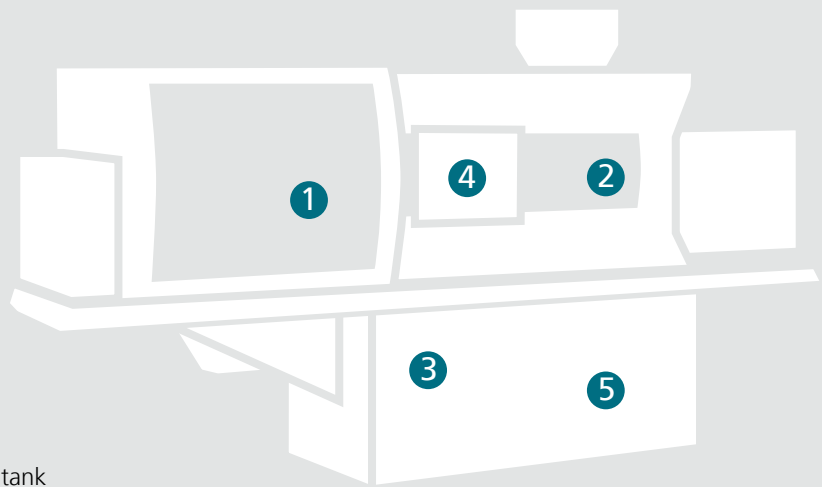

Four-tie bar, retracting clamping system

Despite the many intelligent, balanced components and a multitude of optional equipment, the injection moulding machine from BOY makes do with little floor space (just under 4.7 square metres).

With the BOY 90, BOY was able to present a machine that does more than merely combine all advantages of an innovative concept, proven technology, and ultra-modern control software.

It also stands for efficiency and an unparalleled price/performance ratio. Compared to the competitors, the material throughput of the BOY 90 is markedly higher than that of comparable machines. Further potential for cost-saving are the low energy and maintenance rates - typical for all BOY injection moulding machines.

Required floor space in comparison

BOY 90 = 4,65 m²

6,08 m²*

* Average floor space of nine competitors

BOY insert moulding machines

Solutions for the over-moulding of insert parts

For more than 35 years, BOY has been manufacturing insert moulding machines with vertically arranged clamping units for the over-moulding of insert parts.

The advantages of the insert moulding machines are based on long years of experience with the basic concept of a two-platen clamping unit, which is ideally suited for the purpose. This machine series has proven its value as a reliable means of production worldwide in thousands of applications.

Because of their basic concept, the BOY insert moulding machines feature a very favourable design with regard to ergonomics.

The fixed lower platen is freely accessible. Operating or equipping the BOY insert moulding machines with automation systems or handling units is made a lot easier. Even the integration into complex production lines - for example for the in-line production of predesigned endless belts - can be realized without problems.

Machine concepts of insert moulding machines



- Insert moulding machines with clamping forces of 100, 220, 350, and 550 kN
- Extremely small footprint
- A fixed lower mould platen prevents the insert parts from shifting
- Ideal options for supplementing and automation
- Perfect control by intuitive operation



The BOY insert moulding machines, too, are available in the showroom for individual test series and mould tests.

BOY XSV insert moulding machine

Getting started on insert moulding

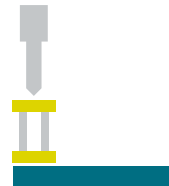

Technical data

EUROMAP size:
100-14

Clamping force:
100 kN

Platen daylight:
250 mm

Opening stroke:
max. 150 mm

Tie bar clearance:
160 mm horizontal
205 mm diagonal

The basic concept of the BOY XS V is identical to the BOY XS, except the injection and clamping units are arranged vertically.

The clamping unit features two diagonally arranged tie bars, which ensures easy access to the mould area. As with all BOY insert moulding machines, the lower platen is fixed. This inhibits a shifting of the inserted parts during mould closing.

The decisive advantages of the BOY XS V are highly precise applications, lowest possible dimensions, and ample space on the machine frame for peripheral equipment. It is ideally suited for fully automatic overmoulding of insert parts and integration into production lines.

- Ultra-compact insert moulding machine with diagonally arranged tie bars.
- Optimum access to the mould area from all four sides
- Best possibilities for inserting and evacuating the parts
- Extremely low space requirement (0.63 m²)

Shot weight (PS):
from 0,1 g until 5,6 g

Strok volume (theoretical):
from 0,1 cm³ until 8,0 cm³

Screw diameter:
12,14 and 16 mm

BOY 22 V insert moulding machine

A versatile, compact machine



The insert moulding machine can be equipped with vertical injection as a BOY 22 V (see photo above) or with the BOY 22 VH, which is designed with horizontal injection for parting line applications (as shown below).



This insert moulding machine can be equipped for vertical injection (BOY 22 VV) or for parting-line injection (BOY 22 VH).

The BOY 22 V insert moulding machine is based on the BOY 22's proven technology. It is suited for manual operation and also for fully automatic over-moulding of insert parts, or for integration into in-line production units. Because of the fixed lower mould platen, easy insertion is guaranteed; furthermore, a shifting of the inserted parts upon closing of the mould is excluded.

- Compact design with a footprint of approx. 1.5 m²
- Space-saving arrangement of peripheral equipment on the machine frame
- Ideal possibilities for automation and integration
- Optional two-hand operation with freely accessible safety gate
- Unparalleled price/performance ratio
- Extremely low operating and energy costs

For special applications which do not allow injecting into the centre of the mould BOY offers the BOY 22 VH, a machine configuration with horizontal injection unit, for parting-line application. Among other things, this ensures that sprue marks are not quite as obvious.



Technical data

EUROMAP size:
220-15 /
220-18 /
220-52

Clamping force:
220 kN

Platen daylight:
400 mm

Opening stroke:
max. 200 mm

Tie bar clearance:
254 mm

Max. shot weight (PS):
61,6 g

Max. stroke volume
(theoretical): 64 cm³

Screw diameter:
14, 18, 22, 24, 28
and 32 mm

BOY 35 V insert moulding machine

Well-proven design

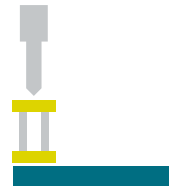

Technical data

EUROMAP size:
350-15 /
350-52 /
350-92

Clamping force:
350 kN

Platen daylight:
500 mm

Opening stroke:
max. 300 mm

Tie bar clearance:
280 x 254 mm

Max. shot weight (PS):
73,7 g

Max. stroke volume
(theoretical): 76,5 cm³

Screw diameter:
14, 18, 22, 24, 28 and
32 mm

The basic concept of the 35 VV is similar to the BOY 22 VV. Its clamping force (350 kN) is higher; also, it features larger distances between tie bars and platens and a higher shot volume. The clamping unit has four tie bars, and the lower platen is fixed. Therefore, a shifting of the insert parts during mould closing is excluded.

Shot weights of up to 73.7 g (PS) for highly precise applications, compact dimensions, ample space for peripheral equipment on the machine frame, as well as the possibility to also use smaller injection units make the BOY 35 VV an ideal solution for fully automatic over-moulding of insert parts.

- Four-tie bar insert moulding machine
- Best possibilities for inserting and demoulding
- Optimum accessibility to the mould from all four sides
- Little space required, due to compact design

BOY 55 V insert moulding machine

Maximum performance

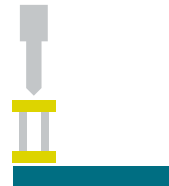

Technical data

EUROMAP size:
550-79 /
550-205

Clamping force:
550 kN

Platen daylight:
550 mm

Opening stroke:
max. 300 mm

Tie bar clearance:
360 x 335 mm

Max. shot weight (PS):
158,9 g

Max. stroke volume
(theoretical): 166,3 cm³

Screw diameter:
24, 28, 32, 38 and 42 mm

With the development of the BOY 55 VV insert moulding machine, BOY tops off its machine programme with a universal insert moulding machine. Compact dimensions and ample space on the machine frame for peripheral and optional equipment ensure optimum integration

possibilities for automation systems. Generous distances between tie bars furthermore offer enough space for mounting large and multi-cavity moulds.

The BOY 55 disposes of a large shot volume, thus enabling large-volume over-moulding without problems. All in all, five screw diameters are available.

- Largest, four-tie bar insert moulding machine
- Ergonomically favourable table height of 975 mm
- Optimum accessibility to the mould area from all four sides
- Favourable machine hour rates

Perfect results in all areas

Special injection moulding procedure using BOY

In addition to the processing of thermoplastic material, continuous research and developments, as well as close cooperation with customers and renowned specialists helped BOY to become an established supplier for special applications. This way, solutions were developed not only for all customary materials, but also for some unique ones.

Furthermore, BOY offers special machine configurations for various applications - for example for **clean room production** or for economic production of **PET** preforms.



The BOY 22 A with integrated laminar flow box and packaging unit is an economical solution for the clean room production of parts with sterile packaging.

Expert know-how

The specialists at BOY are at all times available to you for working out individual concepts and procedures.

Alternatively, you may test your materials and moulds under real-life conditions in the showroom at BOY.

Elastomer processing

Using special injection units, all customary rubber materials can be processed. Renowned manufacturers in the rubber industry have already taken advantage of this feature for their fully automatic, cost-efficient production.



Liquid silicone rubber processing (LSR)

A variety of applications including the production of seals or baby bottle nipples can be accomplished with among other items, the nozzles BOY developed for sprueless injection moulding. The extended BOY quotation includes metering and pump components.



Thermoset processing

Heat resistance and electrical insulation are the advantages of thermoset parts. Our programme contains specific plasticizing units for the production of such items. With specially developed geometries, all mouldable thermoset materials can be processed on BOY injection moulding machines.



Insert technique

This special application can be carried out quickly, precisely, and safely with BOY insert moulding machines. The fixed lower platen, being a structural advantage of this series, prevents shifting of the parts when closing the mould.



PIM

Plasticizing units especially developed by BOY are available for ceramic and metal powder processing. In close cooperation with moulders, solutions have been designed that have proven to be well suited for the application.





Spritzgiessautomaten

Quality without compromise Competence and commitment



Strict and systematic controls of all incoming goods, highest quality standards during production, as well as several days of practical tests prior to delivery ensure BOY's exemplary quality level. Since 1994 the production, sales, and service departments of BOY have been certified according to DIN EN ISO 9001.

It is the staff of BOY who is responsible for the reliability of all injection moulding machines. Each staff member's motivation to produce exemplary quality became the decisive factor for the company's success. Therefore, involving all those connected with the production process is the basic measure of how BOY achieves and defines quality.



BOY has been certified according to DIN EN ISO 9001:2008 since 2010.

Dr. Boy GmbH & Co. KG
Neschener Str. 6
53577 Neustadt-Fernthal
Germany

Tel.: +49 / 26 83 / 3 07 - 0
Fax: +49 / 26 83 / 3 27 71
Internet: www.dr-boy.de
E-Mail: info@dr-boy.de